

MODELS 41-295, 41-300 AND 41-315X

SPECIFICATIONS

Models 41-295, 41-315X and 41-300 are alternating current (A. C.) operated super-heterodyne radios incorporating Electric Push-Button and Manual Tuning, and the new Philco Built-in American and Overseas Aerial system. These models are also designed to receive the sound of a television program tuned in by special type Philco television radios. The models are exceptionally sensitive and selective on all tuning frequencies covered.

In general, these models are similar with the exception of the number of tubes used and cabinet design. Model 41-295 employs eleven (11) tubes and Model 41-300, twelve (12) tubes. Other features of design included in each model are: Philco Loktall tubes; new noise-reducing converter tube (XXL); four (4) tuning bands; two I. F. stages; continuously variable tone control; audio bass compensation in the volume control circuit; degenerative push-pull pentode audio output, operated by a push-pull driver stage; movable band indicator; off-on power switch controlled by a push-button and a new 14" balanced field electro-dynamic speaker.

ELECTRIC PUSH-BUTTON TUNING: The automatic tuning mechanism of each model is identical and consists of eight (8) electric tuning push-buttons; seven (7) of the push-buttons are used for selecting broadcast stations, and one as the power control (On-Off switch).

The lowest frequency station push-button labeled "Television" can be adjusted for reception of the sound channel of a television program received by Philco television sets. This push-button may also be used in conjunction with a Philco Wireless Record Player.

AERIAL CONNECTIONS: The built-in loop aerial system is designed to operate without an outside aerial or ground, and to give exceptionally sensitive receiving performance on stations on standard and shortwave frequencies. Another feature is its noise-reducing characteristic. The loop can be turned to the position in which it picks up a minimum amount of

interference, or if interference is not present, the loop may be set in the position where best reception is obtained.

When operating the radio in steel reinforced buildings and other shielded locations, the Philco 1941 Outdoor Aerial Part No. 45-2817, is recommended for maximum receiving performance. The outdoor aerial can be easily connected to the radio by inserting the plug attached to the transformer unit into the socket provided at the rear of the chassis. This aerial can be obtained from your local Philco distributor. A ground connection is not required with either type of installation.

POWER SUPPLY: 115 volts, 60 cycle A. C.

These models can also be operated on 25 cycle current. To do this it is necessary to replace the 60 cycle power transformer with a 25 cycle transformer as indicated in the parts lists.

POWER CONSUMPTION:

Model 41-295 — 110 watts

Model 41-300 — 110 watts

FREQUENCY TUNING RANGES: 540 to 1720 K. C.; 2.3 to 7.0 M. C.; 9.0 to 12.0 M. C.; 13.5 to 18.0 M. C.

INTERMEDIATE FREQUENCY: 455 K. C.

AUDIO OUTPUT: 5 watts.

PHILCO TUBES USED: Model 41-295, Eleven tubes: XXL, R. F. Mixer; XXL, oscillator; two 7B7, I. F. amplifiers; 7C6, 2nd detector, 1st audio, A. V. C.; two 37, audio drivers; 37, phase inverter; two 42, audio output; and an 80, rectifier.

Model 41-300, Twelve tubes: XXL, R. F. Mixer; XXL, oscillator; two 7B7, I. F. amplifiers; 7A6, 2nd detector, A. V. C.; 7C6, 1st audio; 37, phase inverter; two 37, audio drivers; two 42, audio output; and an 80, rectifier.

CABINET DIMENSIONS:

Model	Height	Width	Depth
41-295	35½"	35"	13½"
41-300	35½"	35½"	14"

REMOVING CHASSIS

To remove the chassis from the cabinet, it will be necessary to take off the bezel and remove the two screws which hold the front of the chassis to the cabinet. In addition, the four shipping bolts underneath the chassis shelf must also be removed.

See Page 27 for Push-button Adjustments.

PRODUCTION CHANGES

To increase the frequency coverage of the middle push-buttons, the compensator strip assembly (13) on the diagram was changed from Part No. 31-6361 to No. 31-6400.

To improve the sensitivity of these models the second I. F. coil, (37 on schematic diagram) was changed from Part No. 32-3494 to Part No. 32-3628.

In making the above coil change, it will be necessary to do the following: The ground straps of the first and second 7B7 tubes are separated. The first 7B7 I. F. tube grounds to the ground lug on the panel opposite the first I. F. coil. The cathode of the second 7B7 I. F. tube is by-passed by resistor (38) and condenser (39) to ground at the ground lug for this tube. Electrolytic condenser (33) is ground to the ground lug of the first 7B7 I. F. tube.

Model 41-315X

Model 41-315X incorporates the same chassis as is used in Model 41-300X, and is assembled in a cabinet similar to Model 41-316RX. The service information for Model 41-300X applies to Model 41-315X with the exception of the several parts changes as follows:

Bezel	40-6627
Screw	W-2073
Cabinet	10501B
Loop	76-1182
Sleeve	28-3806
Sleeve	56-1545
Sleeve	56-1907
Spring Washer	28-4186
Washer	W-151
Screw	W-288
Washer	W-425

PORTION WITHIN DOTTED LINE
FOR 41-295 ONLY
SEE INSERT FOR 41-300

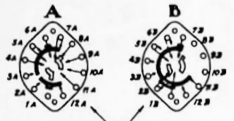
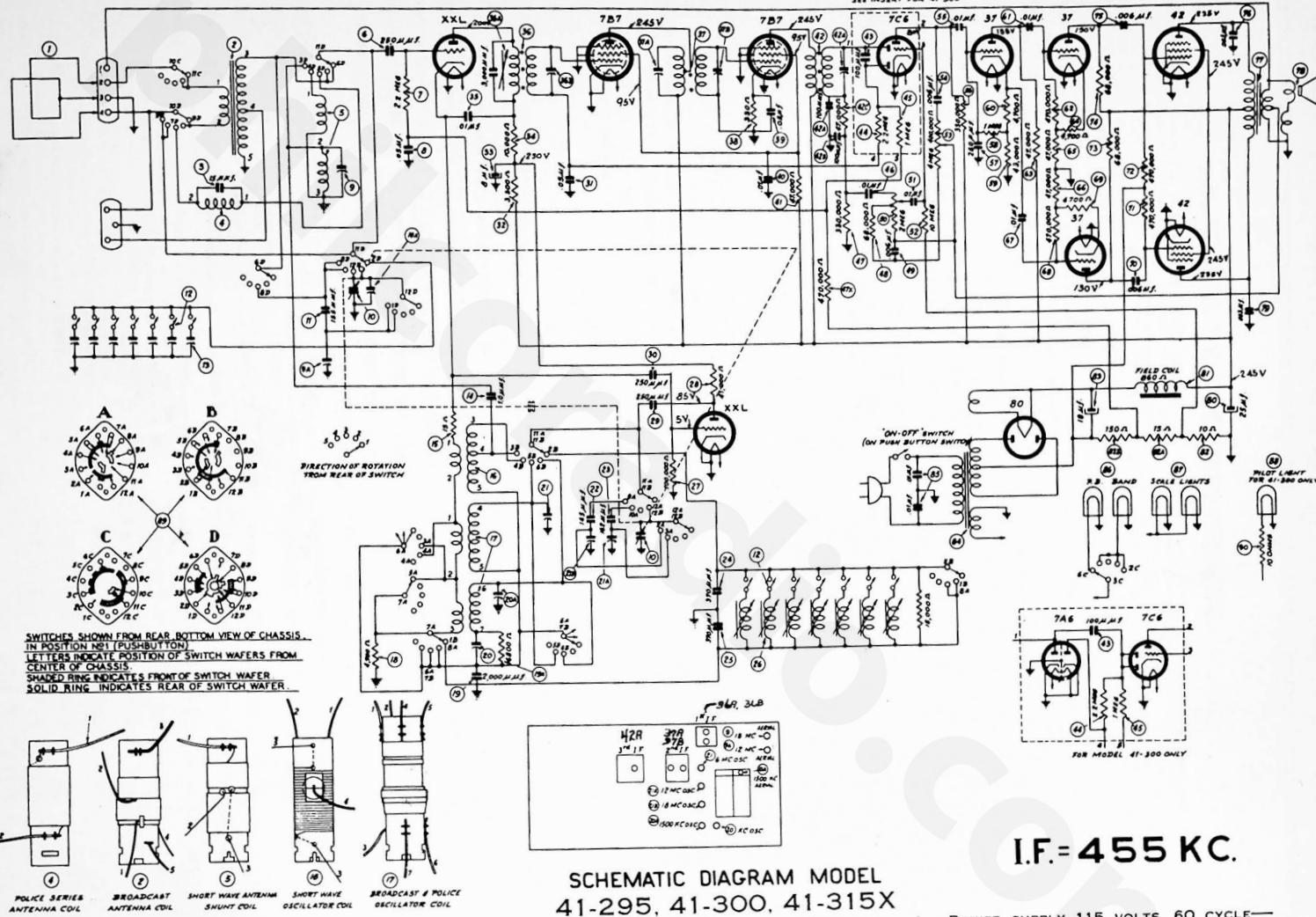

DIRECTION OF ROTATION
TROUGH REAR OF SWITCH

SWITCHES SHOWN FROM REAR BOTTOM VIEW OF CHASSIS
IN POSITION NEAR PUSHBUTTON
LETTERS INDICATE POSITION OF SWITCH WAFERS FROM
CENTER OF CHASSIS
SHADED RING INDICATES FRONT OF SWITCH WAFER
SOLID RING INDICATES REAR OF SWITCH WAFER

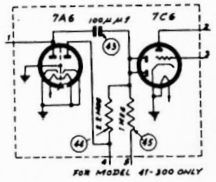
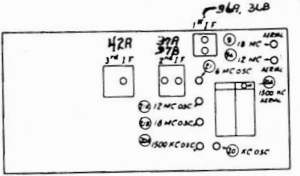
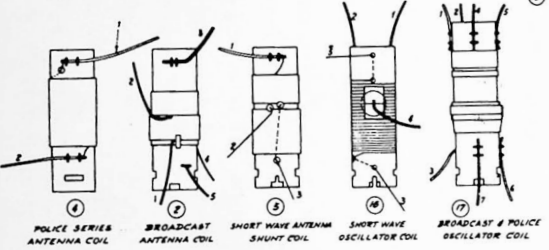

SCHEMATIC DIAGRAM MODEL
41-295, 41-300, 41-315X

I.F. = 455 KC.

THE VOLTAGES INDICATED WERE MEASURED WITH A PHILCO MODEL 027 VOLTMETER (1000 OHMS PER VOLT) — POWER SUPPLY 115 VOLTS, 60 CYCLE — VOLUME CONTROL MINIMUM — NO SIGNAL BEING RECEIVED — RANGE SWITCH "BROADCAST".
THE ABOVE DIAGRAM IS THE COMPLETE ELECTRICAL CIRCUIT FOR MODEL 41-295. THE SAME GENERAL CIRCUIT IS ALSO USED IN MODEL 41-300 WITH THE EXCEPTION OF THE ADDITIONAL 7A6 TUBE IN THE 2ND DETECTOR A. V. C. CIRCUIT. THE WIRING OF THE ADDITIONAL TUBE IS SHOWN IN THE LOWER RIGHT CORNER OF THE SCHEMATIC.

MODELS 41-295, 41-300 AND 41-315X (CONTINUED)

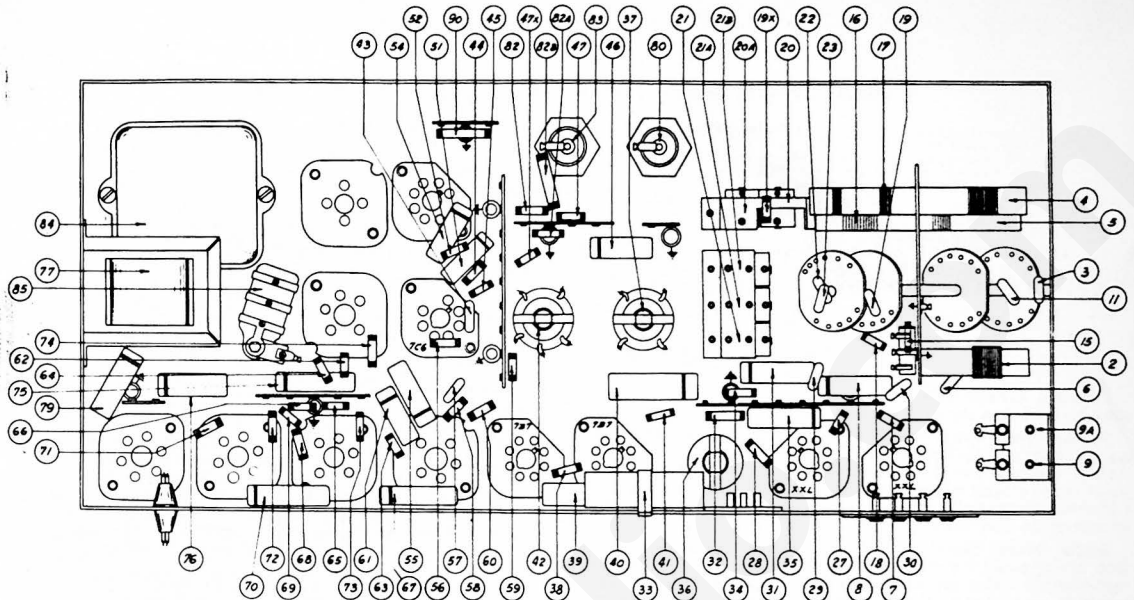

PART LOCATIONS — UNDERSIDE OF CHASSIS

Replacement Parts — Models 41-295, 41-300, 41-315X

SCHE. No.	DESCRIPTION	PART No.	SCHE. No.	DESCRIPTION	PART No.
1	Loop Aerial	76-1089	52	Resistor (10 megohms)	33-610339
	Sleeve (1 required)	56-1907	53	Tone Control	33-5323
	Sleeve (2 required)	28-2257	54	Condenser (.006 mfd., 400 volts)	30-4572
	Spring Washer	28-4186	55	Condenser (.01 mfd., 400 volts)	30-4572
	Washer	W-151	56	Resistor (1 megohm)	33-40039
	Screw	W-288	57	Mica Condenser (.250 mfmfd.)	60-125157
2	Aerial Transformer (Broadcast)	32-3496	58	Resistor (4700 ohms)	33-247339
3	Mica Condenser (.15 mfmfd.)	60-015337	59	Resistor (.43 000 ohms)	33-43339
4	Aerial Transformer (Police)	32-3496	60	Resistor (1 megohm)	33-247339
5	Aerial Transformer (Short Wave)	32-3497	61	Condenser (.01 mfd., 400 volts)	30-4572
6	Mica Condenser (.250 mfmfd.)	60-125157	62	Resistor (470,000 ohms)	33-447339
7	Resistor (2.2 megohms)	33-522339	63	Resistor (47,000 ohms)	33-347339
8	Condenser (.05 mfd., 200 volts)	30-4519	64	Resistor (4700 ohms)	33-247339
9	Compensator (Aerial, 18 M. C.)	31-6359	65	Resistor (68,000 ohms)	33-347339
9A	Compensator (Aerial, S. W., 12 M. C.)	31-6359	66	Resistor (47,000 ohms)	33-347339
10	Tuning Condenser	31-2291	67	Resistor (4700 ohms)	30-4572
	Grommet (Mounting)	27-4771	68	Resistor (470,000 ohms)	33-447339
	Cable Drum and Shaft Assembly	38-9716	69	Condenser (.101 mfd., 400 volts)	33-247339
10A	Comp. (Aerial, 1500 K. C.) Part of 10	30-1176	70	Resistor (470,000 ohms)	33-447339
11	Mica Condenser (.155 mfmfd.)	60-1176	71	Resistor (470,000 ohms)	33-447339
12	Push-button and Power Switch Assm.	42-1592	72	Resistor (68,000 ohms)	33-368339
	Grommet (Push-button Mounting)	27-4586	73	Resistor (68,000 ohms)	33-368339
	Sleeve (Push-button Mounting)	28-3806	74	Condenser (.008 mfd., 1000 volts)	30-4591
13	Push-button Compensators Strip Assm.	31-6361	75	Condenser (.003 mfd., 1000 volts)	30-4469
	Cond. (1 mfmfd., Short Wave and Lug from Wafer Cont. 3D to Wafer Cont. 3B)	31-6361	76	Output Transformer	32-7981
14	Resistor (15 ohms)	33-015337	77	Cone Assembly (For Speaker 36-1515-2)	36-4173
15	Oscillator Transformer (Short Wave)	32-3500	78	Condenser (.003 mfd., 1000 volts)	30-4469
16	Oscillator Trans. (Broadcast, Police)	32-3499	80	Field Coil (Replace Speaker 36-1515)	30-2333
18	Resistor (4700 ohms)	33-247339	81	Electrolytic Condenser (25 mfd.)	33-103336
19	Condenser (2000 mfmfd.)	60-200224	82	Bias Resistor (15 ohms)	33-447339
19A	Resistor (6800 ohms)	33-268339	83	Bias Resistor (115 ohms)	33-115336
20	Compensator (12 M. C., Oscillator)	31-6365	84	Electrolytic (.18 mfd.)	30-2472
20A	Comp. (1500 K. C., Oscil., Part of 20)	31-6365	85	Power Transformer (115 volts, 60 cycle)	33-115
21	Compensator (6 M. C., Oscillator)	31-6362	86	Power Transformer (115 volts, 25 cycle)	32-8151
21A	Compensator (12 M. C., Oscillator)	30-1177	87	Power Trans. (115/220 volts, 60 cycle)	32-2007
21B	Compensator (18 M. C., Oscillator)	30-1177	88	Condenser (.01, .01 mfd.)	3903-00Q
22	Mica Condenser (.162 mfmfd.)	30-1178	89	Pilot Lamp (Right Hand Drum Indicator)	34-2064
23	Mica Condenser (.162 mfmfd.)	30-1178	89	Pilot Lamp (Scale Lights)	34-2064
24	Mica Condenser (.170 mfmfd.)	30-1157	90	Pilot Lamp (Cabinet 41-300 only)	34-2210
25	Mica Condenser (.170 mfmfd.)	30-1157	91	Band Switch	42-822
26	Push-button Oscillator Transformers Assembly (7 Transformers)	32-3477	92	Resistor (10 ohms) Model 41-300 only.	33-104036
26A, B, C, D, E	Push-button Oscillator Transformer (1, 2, 3, 4, 5 Push-buttons)	32-3042			
26F, G	Push-button Oscil. Trans. (6, 7 P. B.)	32-3041			
	Iron Core	28-6916			
	Centering Cup	28-6936			
	Coil Mounting Spring	28-8910			
27	Resistor (47,000 ohms)	33-410339			
28	Mica Condenser (.15 mfmfd.)	60-125157			
30	Mica Condenser (.250 mfmfd.)	60-125157			
31	Condenser (.005 mfd., 400 volts)	30-4572			
32	Resistor (3300 ohms)	33-233439			
33	Electrolytic Condenser (.8 mfd.)	30-2473			
34	Resistor (10,000 ohms)	33-110339			
35	Condenser (.01 mfd.)	30-4572			
36	1st I. F. Transformer	32-3493			
37	2nd I. F. Transformer	32-3494			
38	Resistor (250 ohms)	33-232336			
39	Condenser (.05 mfd., 200 volts)	30-4495			
40	Condenser (.01 mfd., 400 volts)	33-110339			
41	Resistor (47,000 ohm vol.)	33-447339			
42	3rd I. F. Transformer	32-3495			
43	Mica Condenser (.101 mfd.)	60-101157			
44	Resistor (2.2 megohms)	33-522339			
45	Resistor (1 megohm)	33-40039			
46	Condenser (.01 mfd., 400 volts)	30-4572			
47	Resistor (1 megohm)	33-40039			
48	Resistor (68,000 ohms)	33-433339			
49	Volume Control (25 megohms)	32-3893			
50	Condenser (.008 mfd., 400 volts)	30-4591			
51	Condenser (.01 mfd., 400 volts)	30-4572			

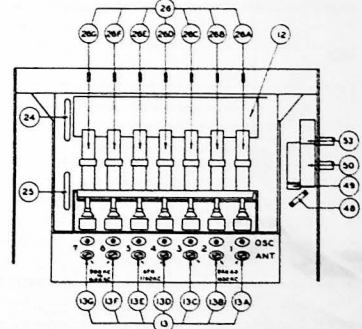

PART LOCATIONS
ELECTRIC PUSH-BUTTON TUNING UNIT

SCHE. No.	DESCRIPTION	PART No.
1	Jewel (Cabinet Pilot Lamp-Cabinet)	27-4777
2	Knob (Push button)	34-6009
3	Rubber Grommet (Chassis Mounting)	37-4871
4	Rubber Grommet (Tuning Unit Mounting)	3814
5	Rubber Grommet (Tuning Unit Mounting)	3913
6	Rubber Corner (Chassis Mounting)	27-4564
7	Socket (6 prong)	27-6058
8	Socket (6 prong)	27-6058
9	Socket (4 prong)	27-6058
10	Socket (Lokalt-Rubber-Oscillator)	27-6129
11	Socket (Lokalt-Bakelite)	27-6131
12	Socket (3 prong)	27-6148
13	Socket (Pilot Lamp-Dial)	38-0905
14	Socket (Pilot Lamp-Cabinet 41-300)	38-0904
15	Speaker	36-1515
16	Tab Kit (Stations)	27-6048
17	Tab (Pre-view)	27-6048
18	Tab (Off-On)	27-6047
19	Washer (Chassis Mounting)	28-8114

ALIGNING R. F. AND I. F. COMPENSATORS

The following procedure is the same for both models:

EQUIPMENT REQUIRED

1. **SIGNAL GENERATOR:** Covering the frequency range of the receiver, such as Philco Models 077 or 177.
2. **ALIGNING INDICATOR:** Either a vacuum tube voltmeter or an audio output meter may be used as an aligning indicator. Philco Models 027 and 028 circuit testers contain both these meters.
3. **TOOLS:** Philco Fiber Screw Driver, Part No. 45-2610.

CONNECTING ALIGNING INSTRUMENTS

Either a vacuum tube voltmeter or an audio output meter may be used as a signal indicator when adjusting the receiver.

Vacuum Tube Voltmeter: To use the vacuum tube voltmeter as an aligning indicator, make the following connections: Attach the negative (—) terminal of the voltmeter to any point in the circuit where the A. V. C. voltage can be obtained. Connect the positive (+) terminal of the vacuum tube voltmeter to the chassis.

Audio Output Meter: Terminal No. 1 is provided on the loop aerial panel for connecting one lead of the audio output meter to the voice coil of the speaker. The other lead of the meter is connected to the chassis. When using these connections, the lowest A. C. scale of the meter must be used. (0 to 10 volts).

The audio output meter can also be connected between the plate of the output tube and the ground of the chassis.

Signal Generator: When adjusting the "I. F." padders, the high side of the signal generator is connected through a .1 mfd. condenser to terminal 4 of the loop aerial terminal panel at the rear of the chassis. The ground or low side of the signal generator is connected to the ground of the receiver.

When aligning the R. F. padders a signal is made from a few turns of wire and connected to the signal generator output terminals; the loop is then placed two or three feet from the loop in the cabinet. Do not remove the receiving loop from the cabinet. It is necessary when adjusting the padders, that the receiver be left in the cabinet.

After connecting the aligning indicator, adjust the compensators in the order shown in the tabulation below. Locations of the compensators are shown on the schematic diagram. If the output meter pointer goes off scale when adjusting the compensators, reduce the strength of the signal from the generator.

Operations in Order	SIGNAL GENERATOR		RECEIVER			SPECIAL INSTRUCTIONS
	Output Connections to Receiver	Dial Setting	Dial Setting	Control Setting	Adjust Compensators in Order	
1	High Side to No. 4 Terminal Loop Panel	455 K. C.	580 K. C.	Vol. Max. Range Switch "S.W.1" Position	36A, 36B, 37A, 37B, 42A	
2	Use Loop on Generator	1500 K. C.	1500 K. C.	Vol. Max. Range Switch "Brdcat"	20A, 10A	Note A
3	Use Loop on Generator	580 K. C.	580 K. C.	Vol. Max. Range Switch "Brdcat"	20	Roll Tuning Condenser Note B
4	Use Loop on Generator	Repeat Operation No. 2				
5	Use Loop on Generator	6 M. C.	6 M. C.	Range Switch "Police"	21	Note C
6	Use Loop on Generator	12 M. C.	12 M. C.	Range Switch "S. W. 1"	21A, 9A	Note D
7	Use Loop on Generator	18 M. C.	18 M. C.	Range Switch "S. W. 2"	21B, 9	Note E

NOTE A — DIAL CALIBRATION: In order to adjust the receiver correctly, the dial must be aligned to track properly with the tuning condenser. To adjust the dial, proceed as follows: With the tuning condenser closed (maximum capacity), set the dial pointer on the extreme left index line at the low frequency end of the broadcast scale. The arrangement of the drive cable in this position is shown in the schematic.

NOTE B — When adjusting the compensator the receiver Tuning Condenser must be adjusted (rolled) as follows: First tune the compensator for maximum output, then vary the tuning condenser of the receiver for maximum output. Now turn the compensator slightly to the right or left and again vary the receiver tuning condenser for maximum output. This procedure of first setting the compensator and then varying the tuning condenser is continued until maximum output reading is obtained.

NOTE C — Adjust compensator (21) to the Second signal peak from the tight (closed) position. The tuning condenser should also be Rolled when the padder is being adjusted on this peak. See Note B on how to Roll the Condenser.

NOTE D — Adjust compensator (21A) to the First signal peak from the tight (closed) position. If the compensator is correctly adjusted the image signal will be weakly heard by leaving the receiver dial at 12 M. C. and turning the signal generator to 11.090 M. C.

NOTE E — Adjust compensator (21B) to the Second signal peak from the tight (closed) position. If the compensator is correctly adjusted the image signal will be weakly heard by leaving the receiver at 18 M. C. and turning the signal generator to 18.910 M. C. When adjusting compensator (9) roll the tuning condenser. See Note B on how to roll the condenser.

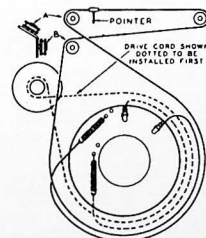

(POINTER AT LOW FREQUENCY END OF DIAL) TUNING CONDENSER MAXIMUM CAPACITY (FULLY CLOSED)

INSTALLATION OF DRIVE CORD